

G-PILOT 3100

AUTOPILOT

Installation Manual

English.....	3
Español.....	32
Português.....	61



Contents

Important	4
1 Introduction	5
1-1 A typical installation	5
1-2 Using the G-PILOT 3100 with other instruments	6
1-2-1 Using other instruments	6
1-2-2 NavBus	6
1-2-3 NMEA.....	6
2 G-PILOT 3100 hardware	7
2-1 What comes with your G-PILOT 3100	7
2-2 Other parts required	8
3 Installation	8
3-1 Installation sequence	8
3-2 Installation guide	9
3-2-1 Location guide.....	9
3-2-2 Wiring guide	9
3-3 Installing the main unit	10
3-4 Installing the power supplies and steering drive	11
3-4-1 Installing the power supplies	11
3-4-2 Installing the steering drive	12
3-5 Installing the rudder feedback unit	16
3-6 Installing the compass.....	19
3-7 Installing the gyro	21
3-8 Installing the display unit and other instruments	23
4 Dockside setup	25
4-1 Start dockside setup.....	25
4-2 Calibrating the rudder feedback unit	26
5 Sea trials	27
5-1 Calibrating the compass.....	27
6 Aligning the compass and the rudder	28
6-1 Aligning the compass	28
6-2 Aligning the rudder	28
Appendix A - Specifications	29
Appendix B - Alarm and warning messages	29
Appendix C - Troubleshooting	31
Appendix D - How to contact us	90

Important

It is the owner's sole responsibility to install and use the instrument and transducer/s in a manner that will not cause accidents, personal injury or property damage. The user of this product is solely responsible for observing safe boating practices.

The choice, location, and installation of all components in any autopilot system is critical. If installation is not correct, the unit can not perform at its designed potential. If in doubt, consult your Navman dealer. Ensure that any holes that cut are in a safe position and will not weaken the boat's structure. If in doubt, consult a qualified boat builder.

Using the G-PILOT 3100:

- The G-PILOT 3100 is intended as an aid to save a helmsman from having to steer for long periods of time, not as the main means of steering the boat.
- The G-PILOT 3100 is not intended for use in extreme weather, in adverse conditions or in water near other boats, dangerous waters or land.
- The G-PILOT 3100 can not control the boat better than a helmsman. In adverse conditions steer the boat manually.
- Never leave the helm unattended. Keep a watch at all times. The helmsman should always monitor the course of the boat and the G-PILOT 3100 and be ready to resume steering the boat manually.
- The performance of the G-PILOT 3100 can be affected by the failure of a part, environmental conditions, improper installation and use.

NAVMAN NZ LIMITED DISCLAIMS ALL LIABILITY FOR ANY USE OF THIS PRODUCT IN A WAY THAT MAY CAUSE ACCIDENTS, DAMAGE OR THAT MAY VIOLATE THE LAW.

As Navman is continuously improving this product we retain the right to make changes to the product at any time which may not be reflected in this version of manual. Please contact your nearest Navman office if you require any further assistance.

Governing Language: This statement, any instruction manuals, user guides and other information relating to the product (Documentation) may be translated to, or has been translated from, another language (Translation). In the event of any conflict between any Translation of the Documentation, the English language version of the Documentation will be the official version of the Documentation.

Copyright © 2003 Navman NZ Limited, New Zealand. All rights reserved. Navman is a registered trademark of Navman NZ Limited.

FCC Statement

Note: This equipment has been tested and found to comply with the limits for a Class B digital device, pursuant to Part 15 of the FCC Rules. These limits are designed to provide reasonable protection against harmful interference in a normal installation. This equipment generates, uses and can radiate radio frequency energy and, if not installed and used in accordance with the instructions, may cause harmful interference to radio communications. However, there is no guarantee that interference will not occur in a particular installation. If this equipment does cause harmful interference to radio or television reception, which can be determined by turning the equipment off and on, the user is encouraged to try to correct the interference by one or more of the following measures:

- Reorient or relocate the receiving antenna.
- Increase the separation between the equipment and receiver.
- Connect the equipment into an output on a circuit different from that to which the receiver is connected.
- Consult the dealer or an experienced technician for help.
- A shielded cable must be used when connecting a peripheral to the serial ports.

1 Introduction

Using this manual

This manual describes how to install and set up the G-PILOT 3100. Refer to the separate *G-PILOT 3100 Operation Manual* for information on how to use the G-PILOT 3100.

To install a G-PILOT 3100, you must perform installation, dockside setup and sea trials (see sections 3, 4 and 5).

To fully set up a G-PILOT 3100 after a part has been changed or if a problem is suspected, perform dockside setup and sea trials (see sections 4 and 5).

To verify that the G-PILOT 3100 is operating correctly, perform sea trials (see section 5).

Cleaning and maintenance

Clean the parts of the G-PILOT 3100 with a damp cloth or mild detergent. Avoid abrasive cleaners, petrol or other solvents.

Do not paint any part of the G-PILOT 3100 except for the cables.

1-1 A typical installation

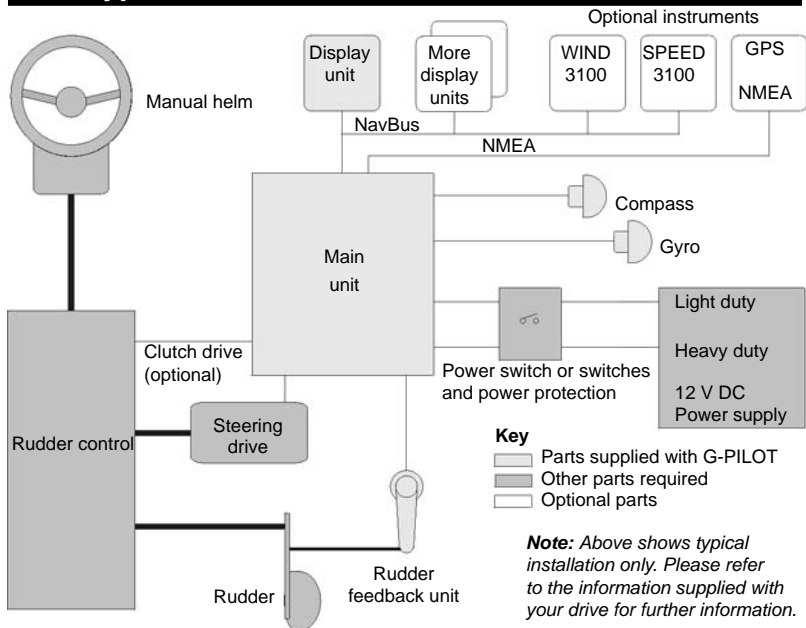

1-2 Using the G-PILOT 3100 with other instruments

1-2-1 Using other instruments

The G-PILOT 3100 can use data from these instruments:

GPS: A GPS or chartplotter, such as a Navman TRACKER 5000 series chartplotter must be connected to the G-PILOT 3100 for the G-PILOT 3100 to operate in **GPS** mode (see the *G-PILOT 3100 Operation Manual*).

Note: *GPS must be via NMEA input.*

WIND: A wind instrument, such as a Navman WIND 3100 series, must be connected to the G-PILOT 3100 for the G-PILOT 3100 to operate in **WIND** mode (see the *G-PILOT 3100 Operation Manual*).

SPEED: A speed instrument, such as:

- Navman's SPEED 3100 with a paddlewheel speed sensor
- or a GPS or chartplotter, such as Navman's TRACKER 5000 series chartplotter can be connected to the G-PILOT 3100 to increase steering accuracy.

Note: *The speed from a paddlewheel sensor is the speed that the boat is moving through the water. The speed from a GPS is the speed over the ground. If there is a water current then these two speeds will be different. If the G-PILOT 3100 is connected to an instrument with a paddlewheel sensor and to a GPS, then the G-PILOT 3100 will automatically use the speed from the paddlewheel sensor instrument.*

1-2-2 NavBus

NavBus is a Navman proprietary system that allows systems of multiple instruments to be built using a single set of transducers. When instruments are connected by NavBus:

- If you change the units, alarms or calibration in one instrument, then the values will automatically change in all other instruments of the same type.
- Each instrument can be assigned to a group of instruments, called a backlight group (see BKL GROUP in the *FACTORY* menu, in the *G-PILOT 3100 Operation Manual*). If you change the backlight in an instrument in group 1, 2, 3 or 4 then the backlight will automatically change in the other instruments in the same group. If

you change the backlight in an instrument in group 0 then no other instruments are affected.

- If an alarm sounds, mute it on any instrument which can display that alarm.
- For more information, refer to the *NavBus Installation and Operation Manual*. **Note:** *GPS must be via NMEA input.*

NavBus and the G-PILOT 3100

- The G-PILOT 3100 will automatically work with additional display units.
- The G-PILOT 3100 can receive wind data from Navman's WIND 3100 over NavBus.
- The G-PILOT 3100 can receive speed data from Navman's SPEED 3100 over NavBus.

1-2-3 NMEA

NMEA is an industry standard, but is not as flexible as NavBus as it requires dedicated connections between instruments. The G-PILOT has one NMEA input port and one port that can be configured to be an input or an output (See *G-PILOT 3100 Operation Manual*).

G-PILOT 3100 NMEA inputs

GPS: The G-PILOT 3100 can receive NMEA GPS data from a compatible GPS or chartplotter, such as Navman's TRACKER 5000 series chartplotter:

- XTE (from APA, APB or XTE sentences) is required for the G-PILOT to use **GPS** mode
- BRG (from APA sentences) and BOD (from APA or APB sentences) are optional and improve performance
- COG (from VTG sentences) is optional and can be displayed.

WIND: The G-PILOT 3100 can receive NMEA wind data from a compatible wind instrument:

- True or apparent wind direction (from MWV sentences) is required for the G-PILOT to use **Wind** mode.

SPEED: The G-PILOT 3100 can receive NMEA speed data from a compatible paddlewheel or GPS instrument:

- SOG (from VTG sentences) is optional and improves performance.

Note: *If the G-PILOT 3100 is connected to a*

Navman 3100 series wind or speed instrument using NavBus, then the G-PILOT 3100 will automatically receive and use the wind or speed data, and the NMEA connection need not be wired.

- either heading (HDG & HDT) and rudder angle (RSA) once per second
- or heading (HDG) ten times per second (see NMEA 2 DAT in the FACTORY menu, See G-PILOT 3100 Operation Manual).

G-PILOT 3100 NMEA outputs

The NMEA 2 port can be configured to be an input or to be output:

2 G-PILOT 3100 hardware

2-1 What comes with your G-PILOT 3100



Main unit



Rudder feedback unit



Display unit



Compass, with 10 m (33 ft) attached cable



Gyro, with 10 m (33 ft) attached cable

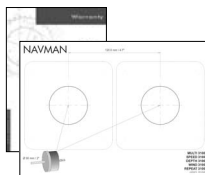

Warranty and display unit mounting template



This Installation manual, Operation manual.



Protective cover for display unit



Mounting hardware, cable cover, strain relief, spare fuses



2 mm (#14) twin stranded cable for high current wiring

2-2 Other parts required

Power supply: The G-PILOT 3100 requires two power supplies, both nominally 12 V DC:

- A heavy duty supply for the steering drive
- A light duty supply for the G-PILOT 3100 electronics and display unit; this supply also powers any additional display units and other instruments.

The power supplies require one or two switches and fuses or circuit breakers (see section 3-4).

Steering drive: The G-PILOT 3100 can power a hydraulic pump, constantly running pump set, hydraulic linear drive or mechanical drive rated at 12 V DC and up to 20 A.

Rudder linkage: To link rudder to rudder feedback unit (see section 3-5).

For wiring, see *Select Wire Table* in section 3-4-2.

External beepers or lights (optional): The external output is switched to ground, 30 V DC and 250 mA maximum. If the beepers and lights require more than 250 mA total, fit a relay.

Other marine instruments (optional): Wind, speed or GPS instruments can be connected (see section 1-2).

Other parts: For systems of several instruments, wiring and connectors are required. Navman junction boxes can simplify wiring several Navman instruments together (see section 1-2 or the *NavBus Installation and Operation Manual*).

Coupling connectors and 10 m (33 ft) extension cables are available to extend the rudder feedback unit, compass or gyro cables. Do not fit more than one extension cable to each unit.

3 Installation

Warning Correct installation is critical to the performance of the unit. It is vital to read this manual and the documentation that comes with the other parts before starting installation.

Warning

- The G-PILOT main unit is not waterproof. Mount the unit in a dry place.
- The G-PILOT display unit is waterproof from the front. Protect the rear of the unit

from water, or else water might enter the breathing hole and damage the unit. The warranty does not cover damage caused by moisture or water entering the back of the unit.

- The compass, gyro and rudder feedback unit are completely waterproof.

Warning Ensure that any holes that you cut will not weaken the boat's structure. If in doubt, consult a qualified boat builder.

3-1 Installation sequence

The recommended installation sequence is:

- 1 Read this manual and the documentation that comes with the other parts.
- 2 Plan the installation: select where the equipment and wiring will be installed (see section 3-2).
- 3 Install the main unit (see section 3-3).
- 4 Install the steering drive and wire the heavy duty and light duty power supplies (see section 3-4).
- 5 Install the rudder feedback unit (see section 3-5).
- 6 Install the compass (see section 3-6).

- 7 Install the gyro (see section 3-7).
 - 8 Install the display unit and any other marine instruments that will be used with the G-PILOT 3100 (see section 3-8).
 - 9 Carry out the dockside setup (see section 4).
 - 10 Carry out the sea trials (see section 5).
- If you are unsure where a part should be installed, mount and wire the part temporarily, without cutting holes in the boat. After the sea trials have been completed, install and wire the part permanently.

3-2 Installation guide

This is a general guide for locating and wiring the parts of the G-PILOT 3100. The instructions for a particular part may have additional requirements.

3-2-1 Location guide

- Do not mount any part where it can be used as a handhold, where it will interfere with the operation of the boat or where it might be submerged.
- Do not mount any part where it will interfere with launching or retrieving the boat.
- Do not mount any part within 0.5 m (20") of the plane of a radar antenna.
- Mount the compass and gyro:
 - At least 1 m (3 ft) away from sources of electrical signals or noise, such as the batteries, high-current cables, other boat cables, engines, fluorescent lights, power inverters, radio or radar transmitters and antennas.
 - At least 1 m (3 ft) away from equipment containing a magnet, such as a compass.

3-2-2 Wiring guide

The G-PILOT 3100 has two kinds of cables:

The heavy-duty power supply and steering drive usually require high-current cables:

- Select the wire gauge from the wire size table (see section 3-4-2).
- Fit high-current cables at least 1 m (3 ft) away from other electronic devices in the boat.
- Keep the cables as short as possible.
- Twin 2 mm (#14) cable is supplied with the G-PILOT 3100 and can be used for the high current cable if its gauge is suitable.

All the other cables are low-current:

- Fit low-current cables at least 1 m (3 ft) away from sources of electrical signals or noise, such as the high-current cables, other boat cables, engines, fluorescent lights, power inverters and radio or radar transmitters and antennas.
- If the cable for the rudder feedback unit, compass or gyro is too long, do not shorten the cable; instead coil the cable up near the main control unit.
- The cable for the rudder feedback unit, compass or gyro can be extended by adding a 10 m (33 ft) extension cable and coupling connector. Do not fit more than one extension cable to each unit.

When fitting any type of cable:

- Do not crush, pinch or strain the cable.
- Secure the cable at regular intervals.
- Ensure no connectors or exposed terminals are in the bilge.

3-3 Installing the main unit

Physical

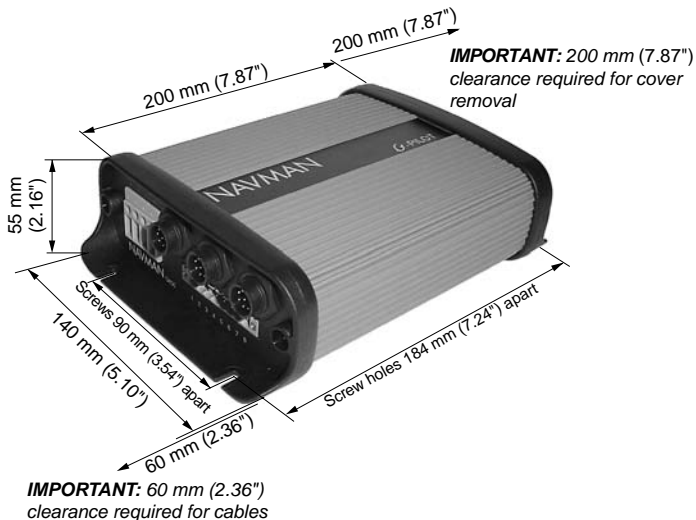

Installation

Find a suitable location for the unit:

- In a dry, cool place; if possible not the engine room.
- Close to the high-current power supply and the steering drive, to reduce the length of the high current wiring.
- Accessible for installation and service.
- If possible on a vertical panel which does not vibrate.
- Follow the location guide (see section 3-2-1).

Mount the unit with the cable connectors at the bottom or to one side, using the screws provided. Do not mount the unit with the connectors at the top, because dust or moisture might enter the unit.

3-4 Installing the power supplies and steering drive

3-4-1 Installing the power supplies

The G-PILOT 3100 requires a light and a heavy duty power supply, both 12 V DC (10.5 to 16.5 V DC).

Note:

- Keep all wiring as short as possible.
- For the heavy duty supply, use the wire size given in the table (see section 3-4-2).
- Follow the wiring guide (see section 3-2-2).

Power supply: one switch configuration

Choose this configuration to have one switch to turn the G-PILOT 3100 and any other instruments on and off.

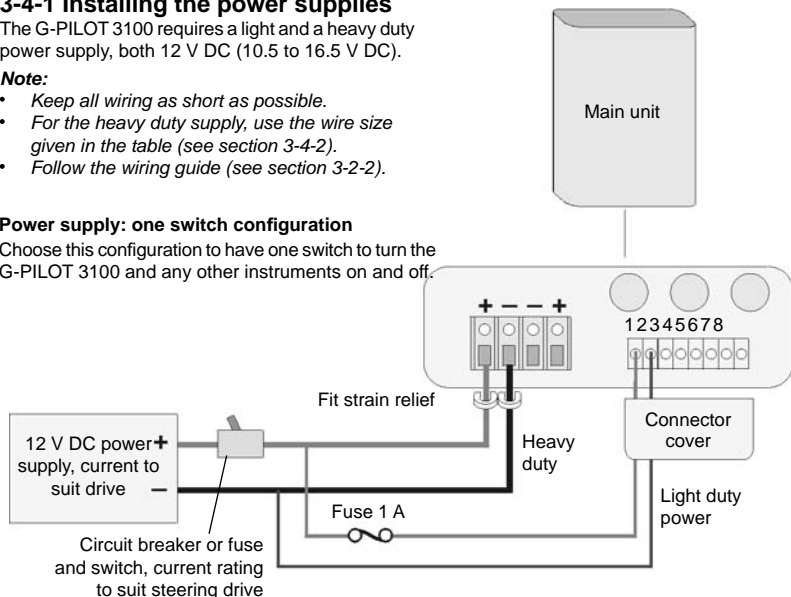

Power supply: two switch configuration

Choose this configuration to be able to turn the drive power off and leave other instruments powered.

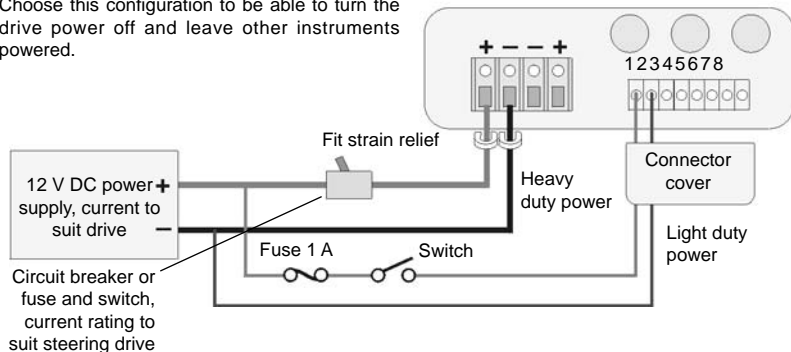

Note: If powering more than three extra display units or other 3100 series instruments, fit another switch and fuse for the light duty power supply for these extra instruments

3-4-2 Installing the steering drive

Install the steering drive according to one of the diagrams on the following pages.

Note

- *Keep all wiring as short as possible.*
- *Use the wire size given in the table below.*
- *Follow the wiring guide (see section 3-2-2).*
- *Wire less than #10 gauge will not fit directly into the four way terminal block. Fit ferrules or reterminate the wire with #10 gauge wire.*
- *If more than one wire is to be fitted to a terminal of the four way terminal block, join the wires together in a suitable way.*

Wire size table

To choose a wire gauge for an installation:

- 1 Measure the length of twin cable required, i.e. the distance from the main control unit to the heavy duty power supply or to the drive.
- 2 Choose the column with the cable length and the row with the circuit current. The intersection of the row and column gives the preferred (minimum) cable wire gauge for less than 3% voltage drop in a 12 V system.

Current	Cable length (from main control unit to power supply or to drive)							
	0.7 m	1.5 m	2.2 m	3 m	3.7 m	4.5 m	5.2 m	6 m
	2.5 ft	5 ft	7.5 ft	10 ft	12.5 ft	15 ft	17.5 ft	20 ft
1 amp	#18	#18	#18	#18	#18	#18	#18	#18
2 amp	#18	#18	#18	#18	#18	#16	#16	#16
3 amp	#18	#18	#18	#16	#16	#16	#14	#14
4 amp	#18	#18	#16	#16	#14	#14	#14	#12
5 amp	#18	#18	#16	#14	#14	#12	#12	#12
6 amp	#18	#16	#16	#14	#12	#12	#12	#10
7 amp	#18	#16	#14	#14	#12	#12	#10	#10
8 amp	#18	#16	#14	#12	#12	#10	#10	#10
9 amp	#18	#16	#14	#12	#12	#10	#10	#10
10 amp	#18	#14	#12	#12	#10	#10	#10	#8
15 amp	#16	#12	#12	#10	#10	#8	#8	#6
20 amp	#14	#12	#10	#8	#8	#6	#6	#6

Example of hydraulic steering with hydraulic help pump.

In the VESSEL menu (See G-PILOT 3100 Operation Manual), set DRIVE TYPE to MTR.

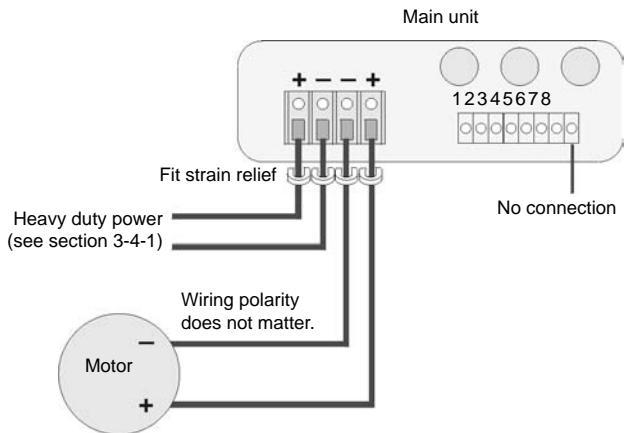

Example of mechanical steered power vessels with hydraulic linear drive for sailing boat

In the VESSEL menu (See G-PILOT 3100 Operation Manual), set DRIVE TYPE to MTR.

Note: Clutch relay coil must draw less than 300 mA

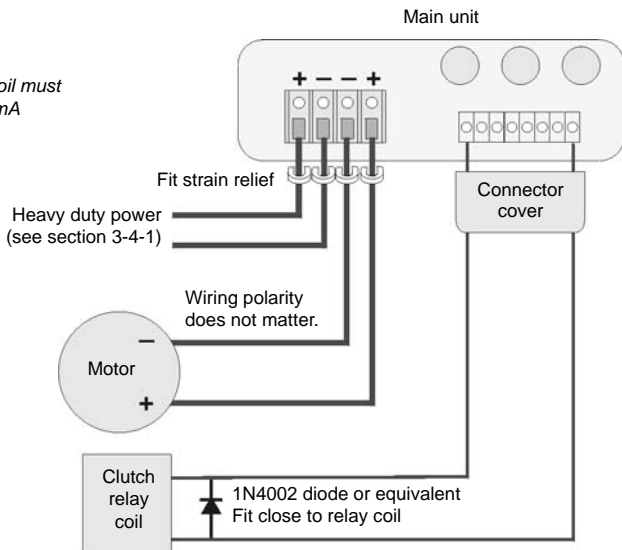

Installing a electric drive motor with clutch relay

In the VESSEL menu (See *G-PILOT 3100 Operation Manual*), set DRIVE TYPE to MTR.

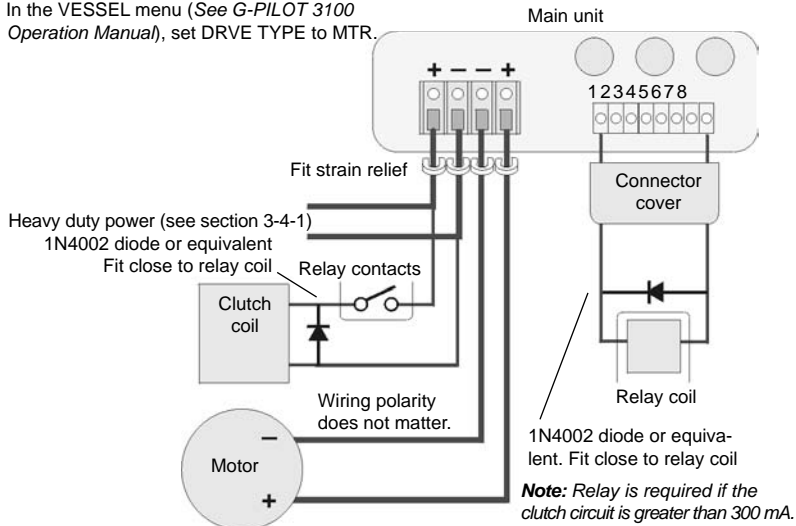

Installing a continuous running pump and solenoid valves.

In the VESSEL menu (See *G-PILOT 3100 Operation Manual*), set DRIVE TYPE to SPL -.

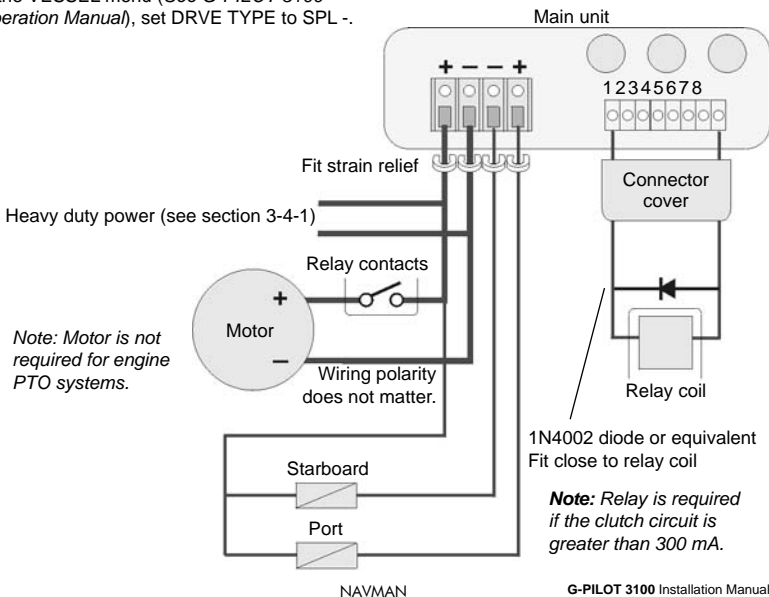

Installing solenoid valves or relays with jog or electric steering

In the VESSEL menu (See *G-PILOT 3100 Operation Manual*), set DRIVE TYPE to SPL -.

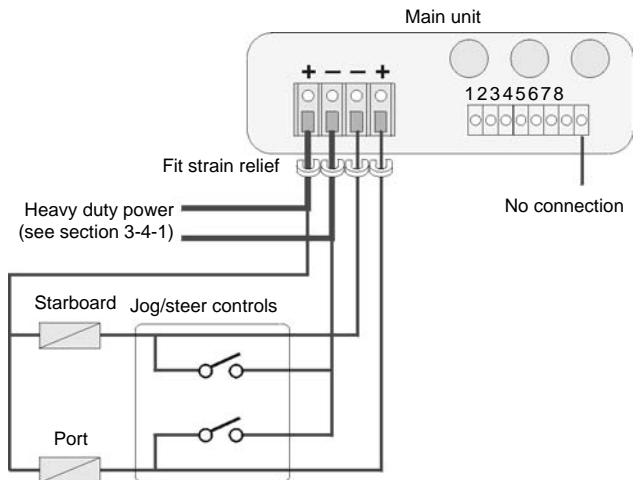

3-5 Installing the rudder feedback unit

Physical

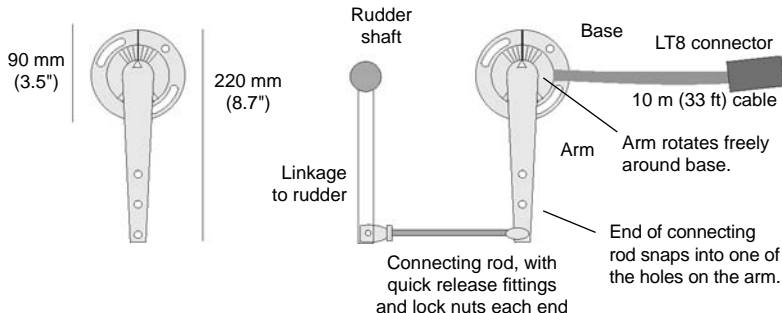

Mounting requirements

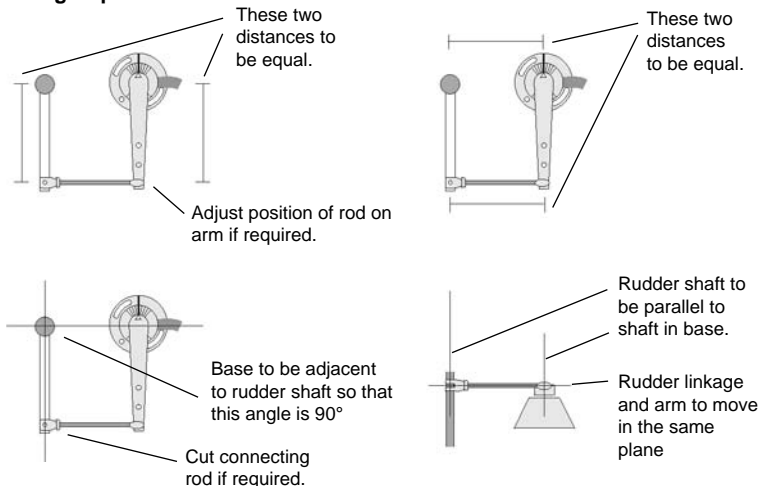

Thread = M5

Note

- The unit is completely waterproof but should not be immersed.
- Mount the unit on a panel which does not vibrate.
- Follow the location guide (see section 3-2-1).

Alignment

The arm can rotate freely around the base. When the rudder is amidships, the arrow on the arm must point to one of the centre lines on the base.

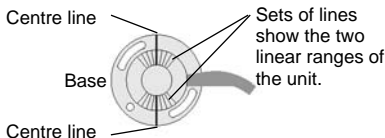

Therefore in an installation, the base can be rotated to two positions. We recommend the position that has the cable on the opposite side to the connecting rod.

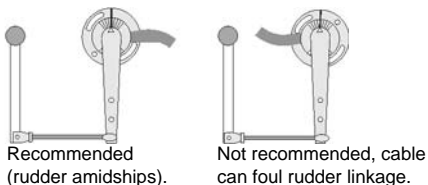

Arrangements

Recommended: U-shaped arrangement with the arm parallel to the length of boat:

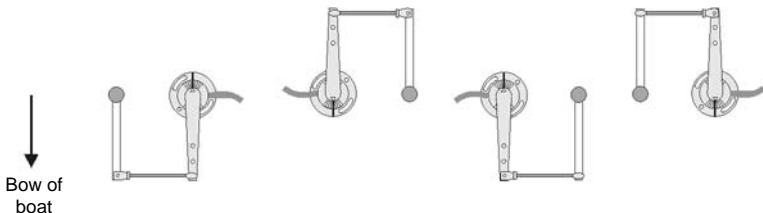

Satisfactory: U-shaped arrangement with arm not parallel to length of boat, for example:

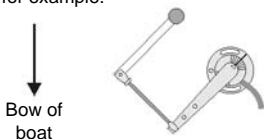

Not recommended: Z-shaped arrangement, for example:

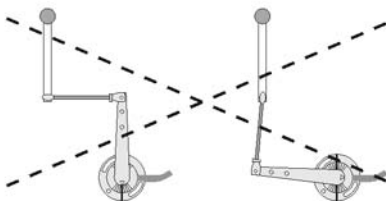

If rudder turns too far, the unit might not return to the Z shape.

Installation

- 1 Find a suitable location and arrangement for the unit as described above.
- 2 Choose, assemble and fit a suitable rudder linkage.
- 3 Fit the unit as shown below:

Set rudder amidships.

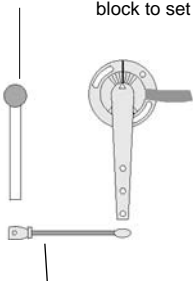

If necessary, cut connecting rod at this end, then replace coupling and lock nut.

If necessary, mount base on block to set height.

Rotate base so arrow on arm points near centre line on base. Fit two screws provided loosely in middle of slots.

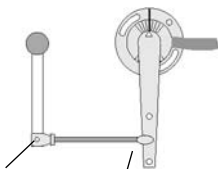

Join coupling to rudder linkage.

Snap end into correct hole in arm.

Rotate base so arrow on arm points to centre line on base. Fit third screw provided, tighten all screws.



Ensure rudder is amidships.

- 4 Wire the cable back to the main unit, following the wiring guide (see section 3-2-2).

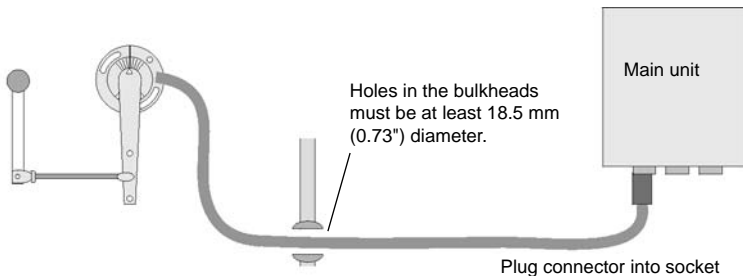

3-6 Installing the compass

Physical

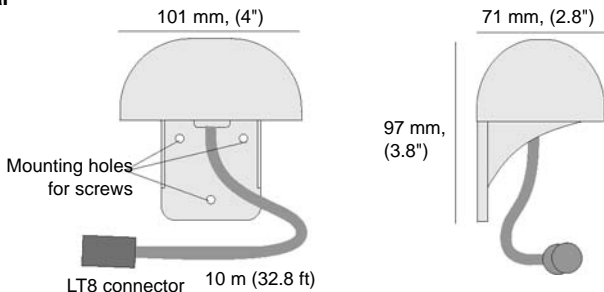

Location

Mount the compass:

- At least 1 m (3 ft) away from any steel or iron boat part, such as:
 - a steel hull, deck, cabin or steel reinforcing in ferro-cement hulls
 - steel equipment such as motors and cooking equipment
 - places where steel objects are stored, such as the anchor locker and storage lockers
- At least 2 m (6 ft) away from equipment with a magnet and equipment which generates electromagnetic fields, such as a compass, a battery, high current wiring,

an electric motor and a radio or radar transmitter or antenna.

- As close as possible to the centre of movement of the boat, to minimise how much the compass moves when the boat rocks and pitches. If the compass can not be mounted at the centre of movement, it is usually best to mount the compass as low as possible.
- On a vertical panel which does not vibrate.

The unit is completely waterproof but should not be immersed. The compass is not affected by other metals, such as stainless steel, copper or brass. Follow the location guide (see section 3-2-1).

Fibreglass or wood hull and cabin: mount compass at the centre of movement (for planing hulls, the centre of movement is usually close to the stern):



Steel hull, non-steel cabin: mount compass 1 m, (3 ft) above hull:

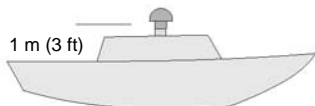

Steel hull and steel cabin: mount compass on a pole 1 m (3 ft) above the hull and at least 1 m (3 ft) from the cabin:

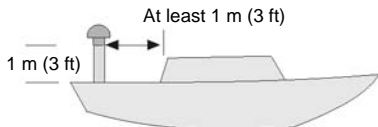

Installation

- 1 Find a suitable location for the unit as described above.
- 2 Mount the unit with the three screws provided. Use a level to ensure the unit is vertical to within 10° .

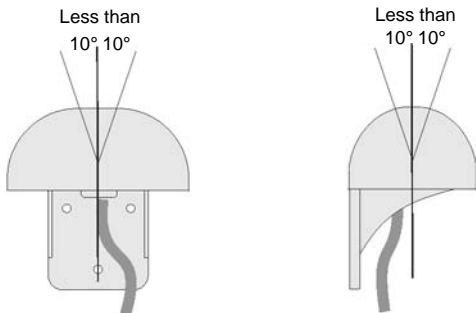

- 3 Wire the cable back to the main unit, following the wiring guide (see section 3-2-2).

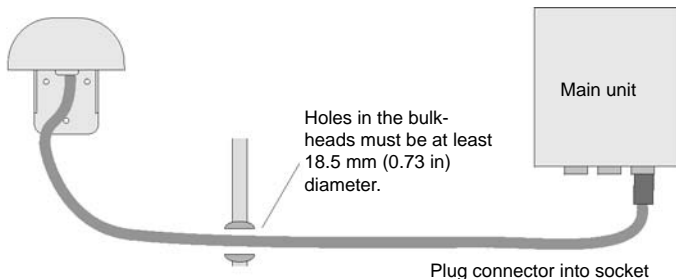

Note

- *If you move the compass with respect to the gyro while the power is on, wait for the heading to stabilize.*

3-7 Installing the gyro

Physical

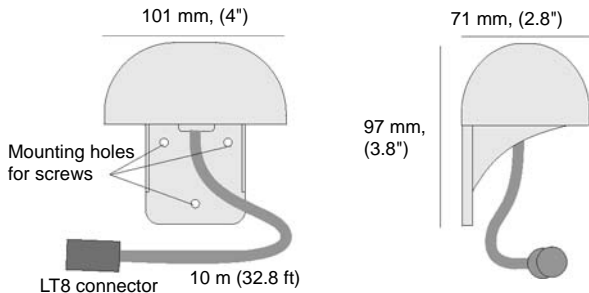

Location

Mount the gyro as close as possible to the centre of movement of the boat, to minimize how much the gyro moves when the boat rocks and pitches.

Mount the gyro on a panel which does not vibrate.

The unit is completely waterproof but should not be immersed. Follow the location guide (see section 3-2-1).

The Ideal location is at the centre of movement (for planing hulls, the centre of movement is usually close to the stern).



Installation

- 1 Find a suitable location for the unit as described above.
- 2 Mount the unit with the three screws provided. Use a level to ensure the unit is vertical to within 10° .

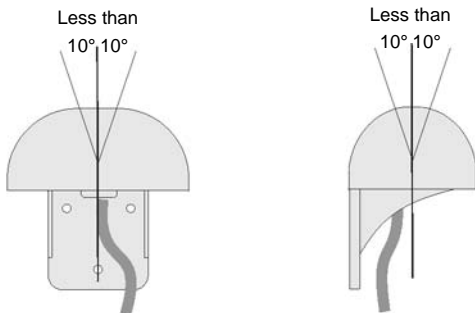

- 3 Wire the cable back to the main unit, following the wiring guide (see section 3-2-2).

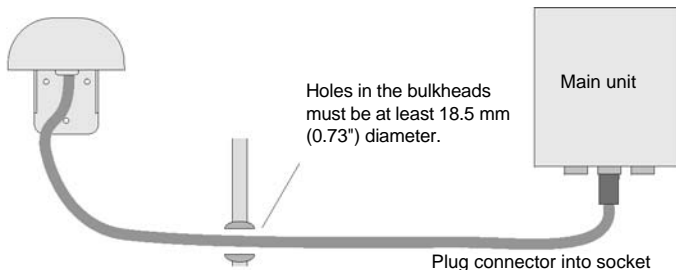

Note

- If you move the gyro with respect to the compass while the power is on, wait for the heading to stabilise.

3-8 Installing the display unit and other instruments

Installing the display unit

- Choose a location for the display unit that is:
 - Easily seen and close to the manual helm.
 - Accessible from behind; the minimum clearance required at the back is 50 mm (2") (see mounting diagram).
 - With the back of the unit protected from moisture.

Follow the location guide (see section 3-2-1).

- The unit must mount on a flat panel which is less than 20 mm (0.75") thick. Stick the mounting template in place. Drill a 50 mm (2") fixing hole through the centre hole in the template. Note that the template allows space around the unit for the protective cover.
- Remove the fixing nut from the back of the unit. Insert the stud at the back of the unit through the mounting hole. Hand tighten the fixing nut.

Side view of display unit mounting

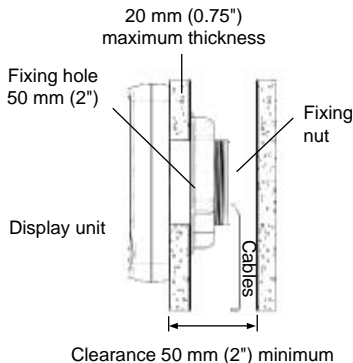

Wiring the display unit

Follow the wiring guide (see section 3-2-2).

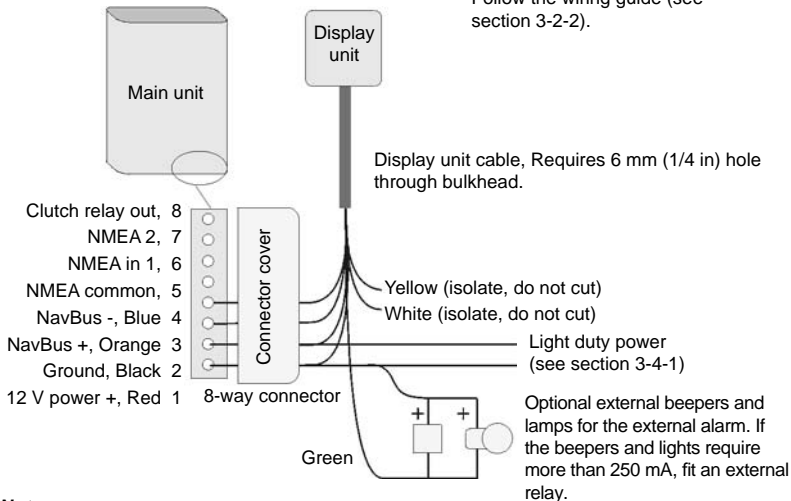

Note

- Wire the display unit power wires (red and black wires) to the eight way connector terminals 1 and 2 to ensure the display unit and main control unit have the same light duty power supply.

Wiring other instruments

Follow the wiring guide (see section 3-2-2).

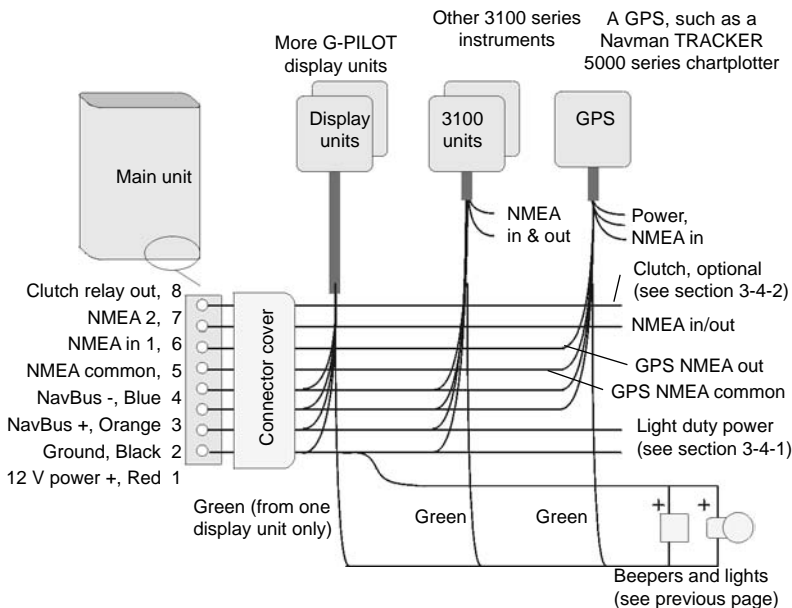

Note:

- Refer to the instrument's installation manual for more wiring information.
- If adding more than three display units or other 3100 series instruments, fit a separate light-duty power supply for the extra instruments (see section 3-4 or the instrument's installation manual)
- The external alarm outputs (green wire) of Navman 3100 series instruments and 5000 series chartplotters can be connected together to drive the external beepers and lights.
- In systems with several other instruments, we recommend using NavBus junction boxes to simplify wiring (see the NavBus Installation and Operation Manual).

4 Dockside setup

Perform the dockside setup:

- after installing a G-PILOT 3100 system (see section 3)
- after a part has been changed or if a problem is suspected

After dockside setup, perform the sea trials (see section 5).

4-1 Start dockside setup

- 1 Turn the G-PILOT 3100 on (See *G-PILOT 3100 Operation Manual*). If the rudder moves, immediately turn the power off (See *G-PILOT 3100 Operation Manual*) and check for incorrect wiring. Check that the display unit shows **AP3100** on the bottom line for a couple of seconds, then the version number, then displays the normal heading display. If you try to enter AUTO and the rudder feedback unit or compass have not yet been calibrated, then the G-PILOT will display CAL ERROR.
- 2 If the G-PILOT 3100 has been used before, reset all user data to the factory defaults:
 - i Go to NVM RESET in the FACTORY menu (See *G-PILOT 3100 Operation Manual*).
 - ii Press **>** to turn the function on.
 - iii Press **MENU** to reset the data.
 - iv Hold **AUTO** to exit the menus.
- 3 Enter the user data listed in the User Data table below (See *G-PILOT 3100 Operation Manual* to find what each data item means and how to enter the data). Beside each item, write the value of the user data that you enter.
- 4 After entering the data, hold **AUTO** to exit the menus.

User Data table (to record installation setup data)

VESSEL menu

Item	Data value
VSL TYPE
DRVE TYPE
WIND TYPE
HDG TYPE
MAG VAR

OPTIONS menu

Menu	Data value
DODGE ANG
TACK ANG
GYBE ANGLE
TACK DELY
TURN RATE

ALARMS menu

Item	Data value
CE ALARM
XTE ALARM
WPT AKN
WND ALARM (SAIL only)
BAT ALARM
CUR ALARM

FACTORY menu

Item	Data value
BKL GROUP
KEY BEEPS
NMEA2 DAT

WARNING

Until the rudder feedback unit is calibrated (see section 4-2), there is no rudder limit. The user must ensure that rudder is not driven onto an endstop when using the jog command (see *G-PILOT 3100 Operation Manual*).

4-2 Calibrating the rudder feedback unit

This procedure matches the rudder feedback unit to the rudder.

Note

- To exit the calibration at any time, press **ESC**.
- If you do not move the rudder as prompted or the rudder feedback unit is not working then the G-PILOT can not finish the calibration. The G-PILOT will display CALB FAIL. Press **ESC**, fix the problem and repeat the calibration.
- In normal operation, the G-PILOT will not turn the rudder closer than 3° to an endstop.

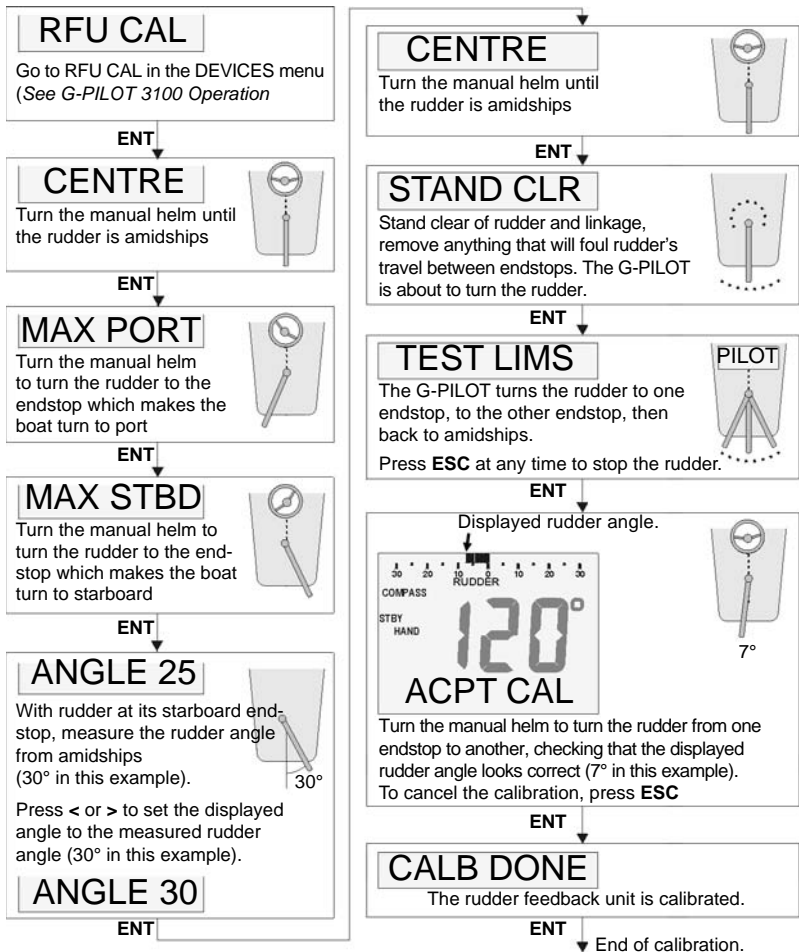

5 Sea trials

Perform the sea trials:

- After performing the dockside setup (see section 4).
- To check the operation of the G-PILOT 3100.

For the sea trials, sail in an open area where there are no other craft or obstructions. The sea should be calm, the wind speed as low as possible and there should be no currents.

5-1 Calibrating the compass

Note

- To exit the calibration at any time, press **ESC**.
- If the boat is not turned as prompted or the compass is not working then calibration can not be completed, the G-PILOT displays **CALB FAIL**. Press **ESC**, fix the problem and repeat the calibration.
- Local disturbances in magnetic field may affect the compass. Calibration must be performed away from large metal structures such as marinas, large ships etc.; this is the responsibility of the user.
- Ensure that both sources are referencing the same north (true or magnetic). If your magnetic compass has not been calibrated then you can use another source for heading. If using vessel's compass then ensure that the deviation tables are applied to check the autopilot's compass.

Turn G-PILOT 3100 on (See G-PILOT 3100 Operation Manual). Use the manual helm to sail a straight course at a slow speed.

CSU CAL

Go to CSU CAL in the DEVICES menu (See G-PILOT 3100 Operation Manual).

TURN BOAT

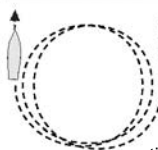

Use the manual helm to make 2.5 turns, steady turn to port or starboard.

Turns should be smooth and continuous in one direction.

Each rotation should take approximately 1 to 2 minutes to perform. The G-PILOT detects when the boat has performed 2.5 rotations and automatically goes to the

This step aligns the compass. If the G-PILOT is connected to a GPS then press MENU twice to skip this step and accept the calibration. Then align the compass to the GPS (see section 6-1-2).

Use an accurate compass or external GPS to find the actual boat heading. If using an external GPS, sail as fast as convenient to ensure the heading is accurate.

Use the manual helm to sail a straight course and ensure the boat heading does not change during this step.

023°
< ALIGN >

For example, actual heading is 20° and displayed heading is 23°.

Press < or > to set the displayed heading to the actual heading (20° in this example).

020°
< ALIGN >



ENT ↓

020°
ACPT CAL

Turn the manual helm to several headings, checking that the displayed heading is close to the actual heading.

To cancel the calibration, press **ESC**.

ENT ↓

CALB DONE

The compass is calibrated.

ENT ↓ End of calibration.

6 Aligning the compass and the rudder

The compass or rudder can be aligned separately.

6-1 Aligning the compass

This aligns the G-PILOT 3100 compass to display the correct heading.

6-1-1 Aligning the G-PILOT 3100 compass to a reference compass

Use an accurate compass or external GPS to find the actual boat heading. If using an external GPS, sail as fast as convenient to ensure the heading is accurate.

Use the manual helm to sail a straight course and ensure the boat heading does not change during this procedure.

Go to ALIGN HDG in the DEVICES menu (See *G-PILOT 3100 Operation Manual*)

ALIGN HDG

ENT

023°
< ALIGN >

For example, actual heading is 20° and displayed heading is 23°.

Press < > to set the displayed heading to the actual heading (20° in this example).

020°
< ALIGN >

ENT

Turn the manual helm to several headings, checking that the displayed heading is close to the actual heading.

End of calibration.

The compass can be aligned either to a reference compass or to a GPS connected to the G-PILOT 3100. Ensure there is no cross-wind or current.

6-1-2 Aligning the G-PILOT 3100 compass to a GPS connected to the G-PILOT

Sail as fast as convenient to ensure the heading is accurate.

Use the manual helm to sail a straight course and ensure the boat heading does not change during this procedure.

Go to ALIGN GPS in the DEVICES menu (See *G-PILOT 3100 Operation Manual*).

ALIGN GPS

ENT

The G-PILOT 3100 records the GPS heading.

6-2 Aligning the rudder

This sets the rudder setting to sail a straight course. Ensure there is no cross-wind or current.

Use the manual helm to sail a straight course at a normal cruising speed.

CENTR RFU

Go to CENTR RFU in the DEVICES menu (*G-PILOT 3100 Operation Manual*).

ENT

The G-PILOT 3100 records the rudder position and sets the rudder angle to zero.

End of calibration.

Appendix A - Specifications

Electrical

- Heavy duty power supply 10.5 to 16.5 V DC, 20 A maximum
- Light duty power supply 10.5 to 16.5 V DC:
 - Main unit: 80 mA.
 - Each display unit, 30 mA without backlighting, 110 mA with full backlighting.
 - Other optional instruments: refer to the instrument's operation manual.

Interfaces

- NavBus connection to other Navman instruments.
- NMEA 0183 outputs: HDG, HDT, RSA; inputs APA, APB, BOD, BWC, MWD, MWV, RMA, RMB, RMC, VHW, VTG, XTE
- NMEA 0183 ports:
 - NMEA 1: Input
 - NMEA 2: Can be programmed to be an input or output

Standards compliance

- EMC compliance
 - USA (FCC): Part 15 Class B.
 - Europe (CE): EN50081-1, EN50082-1
 - New Zealand and Australia (C Tick): AS-NZS 3548.
- Environment:
 - Compass, gyro, rudder feedback unit: completely waterproof.
 - Display unit: IP66 from front when correctly mounted.
 - Main unit: requires a cool, dry, clean environment.

Main unit terminal block connections:

Terminal	Signal
1	Heavy duty power positive, 10.5 to 16.5 V DC, 20 A maximum
2	Heavy duty power negative
3	Steering drive negative output
4	Steering drive positive output

Main unit connector connections:

Terminal	Signal
1	Light duty power positive, 10.5 to 16.5 V DC, 80 mA maximum
2	Light duty power supply common
3	NavBus +
4	NavBus -
5	NMEA common
6	NMEA in 1
7	NMEA in 2
8	Steering clutch relay drive output, switched ground to turn relay on, 30 V DC, 300 mA maximum

Display unit power/data cable wires:

Wire	Signal
Red	Power positive, 10.5 to 16.5 V DC, 30 mA without backlighting, 110 mA with full backlighting
Black	Power negative
Orange	NavBus +
Blue	NavBus -
Yellow	Factory use (isolate, do not cut)
White	Factory use (isolate, do not cut)
Green	External alarm, switched to ground, 30 V DC and 250 mA max.

Appendix B - Alarm and warning messages

Alarm display	Reason for message	Recommended action by user	Notes
BAT ALARM	Battery voltage is less than the minimum value set by the user	Check batteries Disengage G-PILOT if voltage too low	a
CAL ERROR	The G-PILOT rudder feedback unit or compass unit is not calibrated	Calibrate both the units (see sections 5-2 and 6-1)	a
CCH ERROR	The clutch current is too high	Check clutch connection	a s
CE ALARM	Course error has exceeded the maximum value set by the user	Manually steer boat towards course	a
CSU ERROR	Compass not sending data to main unit	Check compass is connected to main unit; Service compass	a s
CUR ALARM	The motor current exceeded the maximum value set by the user	Check steering drive is not jammed Increase the alarm value	a s

Alarm display	Reason for message	Recommended action by user	Notes
DRV ERROR	Rudder angle does not change when steering drive operates	Check drive power is turned on Check RFU is connected to rudder Check fuses inside end of main control unit Check steering drive operation	a s
GPS ERROR	GPS has stopped sending data to main unit	Check GPS operation Check GPS connection	a c s
GSU ERROR	Gyro not sending data to main unit	Check gyro is connected to main unit; Service gyro	a s
MCU ERROR	Main unit not sending data to display unit	Check display unit is connected to main unit Service main unit or display unit	a s
NAV ERROR	GPS is not navigating to a waypoint when trying to engage G-PILOT	Start GPS navigating to a waypoint or along a route	m
NEXT WPT?	Boat has reached a waypoint (in GPS mode and WPT AKN is on)	Press any key to proceed to cancel alarm Then press ENT to start steering to the next waypoint or press ESC to return to	
STBY NO DATA	G-PILOT not receiving GPS data when setting mode to GPS	Check GPS operation Check GPS connection	m
or	G-PILOT not receiving wind instrument data when setting mode to wind	Check wind instrument operation Check wind instrument connection	m
NVM ERROR	Main unit memory has been corrupted	Service main unit	a s
PHA ERROR	Rudder turns wrong way to rudder feedback unit	Check the rudder feedback unit Perform a rudder calibration	a s
RFU ERROR	Rudder feedback unit has stopped sending data to main unit	Check rudder feedback unit is connected to main unit Service rudder feedback unit	a s
ROUTE END	Boat has reached the end of a GPS route	Press ESC to change to STBY or press ENT to change to compass mode, sailing at current heading	
TRK ERROR	G-PILOT has changed to GPS mode but boat is too far off course	Press ESC to return to STBY or press ENT to have the G-PILOT steer the boat to the correct course.	
TAK ERROR	In wind mode, attempt to tack in the wrong way or boat will be in irons	Change angle to wind	m
WND ALARM	The wind angle has changed by more than the alarm value	Change SWA Change to Compass mode	a
WND ERROR	Wind instrument has stopped sending data to main unit	Check wind instrument operation Check wind instrument connection	a c s
XTE ALARM	XTE has exceeded the maximum value set by the user	Manually steer boat towards course	a

Notes	a	Alarm sounds the internal and external (optional) beepers; press any key to mute alarm, then press ESC to cancel the alarm message
	c	The G-PILOT 3100 changes to Compass mode
	m	The G-PILOT 3100 mode does not change
	s	The G-PILOT 3100 changes to STBY

Appendix C - Troubleshooting

This troubleshooting guide assumes that you have read and understood this manual.

It is possible in many cases to solve difficulties without having to send the unit back to the manufacturer for repair. Please follow this troubleshooting section before contacting the nearest Navman dealer.

There are no user serviceable parts. Specialized methods and testing equipment are required to ensure that the unit is reassembled correctly. Repairs to the unit must only be carried out by a service centre approved by Navman NZ Limited. Users who service the unit themselves will void the warranty. More information can be found on our Website: www.navman.com.

- 1 Unit will not turn on:**
 - a Fuse blown or circuit breaker tripped.
 - b Battery voltage is outside the range 10.5 to 16.5 V DC.
 - c Power/data cable damaged.
- 2 G-PILOT 3100 makes too frequent course corrections:**
 - The value of response is too low (see *G-PILOT 3100 Operation Manual*).
- 3 When sailing a straight course, the boat drifts from side to side of the course:**
 - a The boat should drift from side to side of the course when the G-PILOT 3100 steering is optimized.
 - b Change to a profile suitable for boat speed and sea conditions (see *G-PILOT 3100 Operation Manual*).
 - c If the boat drifts too far from the course, adjust response, ratio, counter rudder gain, GPS gain (if G-PILOT is in GPS mode) or wind gain (if G-PILOT is in wind mode) (see *G-PILOT 3100 Operation Manual*).
- 4 When sailing a straight course, the boat drifts off course:**
 - a Change to a profile suitable for boat speed and sea conditions (see *G-PILOT 3100 Operation Manual*).
 - b Adjust response, ratio, counter rudder gain, GPS gain (if G-PILOT is in **GPS** mode) or wind gain (if G-PILOT is in wind mode) (see *G-PILOT 3100 Operation Manual*).
- 5 When making a large course change, boat does not follow the expected course:**
 - a Change to a profile suitable for boat speed and sea conditions (see *G-PILOT 3100 Operation Manual*).
 - b Check turn rate is not too low (go to TURN RATE in the OPTIONS menu, see *G-PILOT 3100 Operation Manual*).
 - c Adjust counter rudder gain (see *G-PILOT 3100 Operation Manual*).
- 6 Boat turns too sharply:**
 - Reduce turn rate (go to TURN RATE in the **OPTIONS** menu, see *G-PILOT 3100 Operation Manual*).
- 7 The word SIMULATE flashes on the display, values displayed are unexpected:**
 - Unit is in simulate mode (See *G-PILOT 3100 Operation Manual*).
- 8 The display fogs:**
 - a Moist air has entered the breathing tube at the rear of the unit. Air the boat or run unit with backlight fully on.
 - b Water has entered the breathing tube. Return unit for service.

NORTH AMERICA

Navman USA Inc.
30 Sudbury Rd, Acton, MA 01720.
Toll Free: +1 866 628 6261
Fax: +1 978 897 8264
e-mail: sales@navmanusa.com
web: www.navman.com

AUSTRALIA

Navman Australia Pty. Limited
Unit 2 / 5-13 Parsons St.
Roselle, NSW 2039, Australia.
Ph: +61 2 9818 8382
Fax: +61 2 9818 8386
e-mail: sales@navman.com.au
web: www.navman.com

OCEANIA

New Zealand
Absolute Marine Ltd.
Unit B, 138 Harris Road,
East Tamaki, Auckland.
Ph: +64 9 273 9273
Fax: +64 9 273 9099
e-mail: navman@absolutemarine.co.nz

Papua New Guinea

Lohberger Engineering,
Lawes Road, Konedobu.
PO Box 810, Port Moresby.
Ph: +675 321 2122
Fax: +675 321 2704
e-mail: loheng@online.net.pg
web: www.lohberger.com.pg

SOUTH AMERICA

Argentina
Costanera Uno S.A.
Av Pte Ramón S. Castillo y Calle 13
Zip 1425 Buenos Aires, Argentina.
Ph: +54 11 4312 4545
Fax: +54 11 4312 5258
e-mail:

purchase@costanerauno.com.ar
web: www.costanerauno.ar

Brazil

Equinatic Com Imp Exp de Equip
Nauticos Ltda.
Rua Ernesto Paiva, 139
Clube dos Jangadeiros
Porto Alegre - RS - Brasil
CEP: 91900-200.
Ph: +55 51 3268 6675
+55 51 3269 2975
Fax: +55 51 3268 1034
e-mail:

equinatic@equinatic.com.br
web: www.equinatic.com.br

Realmarine

Estrada do Joa 3862,
Barra da Tijuca, Rio de Janeiro,
Brazil. CEP: 22611-020.
Ph: +55 21 2483 9700
Fax: +55 21 2495 6823
e-mail: tito@realmarine.com.br
web: www.realmarine.com.br

Chile

Equipmar
Manuel Rodriguez 27
Santiago, Chile.
Ph: +56 2 698 0055
Fax: +56 2 698 3765
e-mail: mmontecinos@equipmar.cl

Mera Vennik
Colon 1148, Talcahuano,
4262798, Chile.
Ph: +56 41 541 752
Fax: +56 41 543 489
e-mail: meravennik@entel.chile.net

CENTRAL AMERICA

Mexico
Mercury Marine de Mexico
Anastasio Bustamante #76
Interior 6 Colonia Francisco Zarabia,
Zapapan, Jalisco, C.P. 45236 Mexico.
Ph: +52 33 3283 1034
Fax: +52 33 3283 1034
web: www.equinautic.com.br

ASIA

China
Peaceful Marine Electronics Co. Ltd.
Guangzhou, Hong Kong, Dalian,
Qingdao, Shanghai
1701 Yanjiang Building
195 Yan Jiang Zhong Rd. 510115
Guangzhou, China.
Ph: +86 20 3869 8839
Fax: +86 20 3869 8780
e-mail: sales@peaceful-marine.com
web: www.peaceful-marine.com

India

Access India Overseas Pvt. Ltd.
A-98, Sector 21,
Noida - 201 301, India.
Ph: +91 120 244 2697
Telefax: +91 120 253 7881
Mobile: +91 98115 04557
e-mail: vkapil@del3.vsnl.net.in
Esmario Export Enterprises
Block No. F-1, 3rd Floor, Surya Towers
Sardar Patel Rd, Secunderbad 500 003.
Ph: +91 40 2784 5163
Fax: +91 40 2784 0595
e-mail: gfieee@hd13.vsnl.net.in
web: www.esmario.com

Indonesia

Polytech Nusantara,
Graha Paramita 2nd Floor,
Jln Denpasar Raya Blok D2
Kav 8 Kuningan, Jakarta 12940.
Ph: +62 21 252 3249
Fax: +62 21 252 3250
e-mail: polytech@transavia.co.id

Korea

Kumhomar Technology Co. Ltd.
#604-842, 2F, 1118-15, Janglim1-Dong,
Saha-Gu, Busan, Korea.
Ph: +82 51 293 8589
Fax: +82 51 265 8984
e-mail: info@kumhomar.com
web: www.kumhomar.com

Maldives

Maizan Electronics Pte. Ltd.
Hemeyru, 08 Sosunmagu.
Male', Maldives.
Mobile: +960 78 24 44
Ph: +960 32 32 11
Fax: +960 32 57 07
e-mail: ahmed@maizan.com.mv

**Singapore, Malaysia, Brunei,
Indonesia and Philippines**
RIQ PTE Ltd.
Blok 3007, 81 Ubi Road 1, #02-440,
Singapore 408701.
Ph: +65 6741 3723
Fax: +65 6741 3746
e-mail: riq@postone.com

Taiwan

Seafirst International Corporation
No. 281, Hou-An Road, Chien-Chen
Dist. Kaohsiung, Taiwan R.O.C.
Ph: +886 7 831 2688
Fax: +886 7 831 5001
e-mail: seafirst@seed.net.tw
web: www.seafirst.com.tw

Thailand

Thong Electronics (Thailand) Co. Ltd.
923/588 Ta Prong Road, Mahachai,
Muang, Samutsakhon 74000, Thailand.
Ph: +66 34 411 919
Fax: +66 34 422 919
e-mail: sales@thongelectronics.com
admins@thongelectronics.com
web: www.thongelectronics.com

Vietnam
Haidang Co. Ltd.
1763 Le Hong Phong St. Ward 12
District 10, Ho Chi Minh City.
Ph: +84 8 863 2159
Fax: +84 8 863 2124
e-mail: sales@haidangvn.com
web: www.haidangvn.com

MIDDLE EAST**Lebanon and Syria**

Balco Stores
Balco Building, Moutran Street,
Tripoli (via Beirut). - Lebanon
P.O. Box: 622.
Ph: +961 6 624 512
Fax: +961 6 628 211
e-mail: balco@cyberia.net.lb

United Arab Emirates

Kuwait, Oman, Iran, Saudi
Arabia, Bahrain & Qatar
Abdullah Moh'd Ibrahim Trading, opp
Creak Rd, Maniyah Road, Dubai.
Ph: +971 4 229 1195
Fax: +971 4 229 1198
e-mail: sales@amitdubai.com

AFRICA**South Africa**

Pertec (Pty) Ltd (Coastal Division)
16 Paarden Eiland Road.
Paarden Eiland, 7405
PO Box 527,
Paarden Eiland, 7420
Cape Town, South Africa.
Ph: +27 21 508 4707
Fax: +27 21 508 4888
e-mail: info@kfa.co.za
web: www.pertec.co.za

EUROPE**France, Belgium and Switzerland**

Plastimo SA
15, rue Ingénieur Verrière,
BP435,
56325 Lorient Cedex.
Ph: +33 2 97 87 36 36
Fax: +33 2 97 87 36 49
e-mail: plastimo@plastimo.fr
web: www.plastimo.fr

Germany

Navimo Deutschland
15, rue Ingénieur Verrière
BP435- 56325 Lorient Cedex.
Ph: +49 6105 92 10 09
+49 6105 92 10 10
+49 6105 92 10 12
Fax: +49 6105 92 10 11
e-mail:

plastimo.international@plastimo.fr
website: www.plastimo.de

Italy

Navimo Italia
Nuova Rade spa, Via del Pontasso 5
16015 Casella Scrvia (GE).
Ph: +39 1096 80162
Fax: +39 1096 80150
e-mail: info@nuovarade.com
web: www.plastimo.it

Holland

Navimo Holland
Industrieweg 4,
2871 JF Schoonhoven.
Ph: +31 182 320 522
Fax: +31 182 320 519
e-mail: info@plastimo.nl
web: www.plastimo.nl

United Kingdom

Navimo UK
Hamilton Business Park
Bailey Road, Hedge End
Southampton, Hants SO30 2HE.
Ph: +44 01489 778 850
Fax: +44 0870 751 1950
e-mail: sales@plastimo.co.uk
web: www.plastimo.co.uk

Sweden, Denmark, Finland and Norway

Balco Nordic
Lundenvägen 2,
473 21 Henån.
Ph: +46 304 360 60
Fax: +46 304 307 43
e-mail: info@plastimo.se
web: www.plastimo.se

Spain

Navimo España
Avenida Narcís Monturiol, 17
08339 Vilassar de Dalt,
Barcelona.
Ph: +34 93 750 75 04
Fax: +34 93 750 75 34
e-mail: plastimo@plastimo.es
web: www.plastimo.es

Portugal

Navimo Portugal
Avenida de India Nº40
1300-299 Lisbon.
Ph: +351 21 362 04 57
Fax: +351 21 362 29 08
e-mail: plastimo@siroco-nautica.pt
web: www.plastimo.com

Other countries in Europe

Plastimo International
15, rue Ingénieur Verrière BP435
56325 Lorient Cedex, France.
Ph: +33 2 97 87 36 59
Fax: +33 2 97 87 36 29
e-mail:
plastimo.international@plastimo.fr
web: www.plastimo.com

**REST OF WORLD/
MANUFACTURERS**

Navman NZ Limited
13-17 Kawana St.
Northcote.
P.O. Box 68 155,
Newton,
Auckland,
New Zealand.
Ph: +64 9 481 0500
Fax: +64 9 481 0590
e-mail: marine.sales@navman.com
web: www.navman.com

Made in New Zealand
MN000212E



G-PILOT 3100 Installation

Lon 174° 44.535'E

NAVMAN

Lat 36° 48.404'S

FC  CE